



ICC Evaluation Service, Inc.
www.icc-es.org

Business/Regional Office # 5360 Workman Mill Road, Whittier, California 90601 # (562) 699-0543
Regional Office # 900 Montclair Road, Suite A, Birmingham, Alabama 35213 # (205) 599-9800
Regional Office # 4051 West Flossmoor Road, Country Club Hills, Illinois 60478 # (708) 799-2305

Legacy report on the BOCA® National Building Code/1999 and the 1998 International One- and Two-Family Dwelling Code®

DIVISION: 02—SITWORK

Section: 02350—Piles and Caissons

EVALUATION SUBJECT:

GRIP-TITE® FOUNDATION PIER SYSTEM

REPORT HOLDER:

GRIP-TITE MANUFACTURING CO., INC.
P.O. BOX 111
WINTERSET, IA 50273
(515) 462-1313
www.griptite.com

EVALUATION SCOPE

Compliance with the following code:

- BOCA® National Building Code/1999
 - # Section 106.4 Alternative materials and equipment
 - # Section 1705.3.1 Inspection of steel fabricators
 - # Section 1705.3.3.2 Welding
 - # Section 1807.1 Design loads
 - # Section 1817.1 Determination of allowable loads
 - # Section 2203.1 General - Structural Steel Construction
- 1998 International One- and Two-Family Dwelling Code®
 - # Section 113.4 Other inspections
 - # Section 401 General - Foundations

DESCRIPTION

General

Grip-Tite® Foundation Pier Systems are used to form deep foundations for new structures, to provide bearing for new foundations, to underpin foundations of existing structures, and to retrofit or remediate deficient foundations of existing structures. Grip-Tite® Foundation Pier System consist of steel push tubes and foundation pier anchoring brackets.

For underpinning or retrofit of existing footings, the push tubes are pushed down below the existing foundation using a hydraulic ram. The friction collar is installed on the first tube entering the soil as a pilot tip. Push tubes are joined end-to-end by a tube shaped coupler which is inserted into one tube end and plug welded in place and then inserted in to the joining

tube, allowing for deeper pier depths to be reached. After all the push tubes are installed, the bracket assembly is secured to the last push tube assembly and to the foundation, thereby providing support for the existing structure. The foundation pier anchoring brackets join the steel push tubes to the foundation of the structure through friction force. See Figure 1 of this report for an illustration of an installed Grip-Tite® Foundation Pier System.

Push Tube Assembly

Push tube assemblies consist of:

Tube: A tube manufactured from 3 in. o.d. x 0.120 in. thick (76 mm x 3.1 mm) high strength/low alloy hot rolled steel conforming to ASTM A513, Grade HSLA HR BLK with a minimum tensile strength of 80,000 psi (551 MPa) and a minimum yield strength of 70,000 psi (483 MPa). Tube sections come in lengths of 3 ft (914 mm).

Coupler: A coupler manufactured from 2.75 in. o.d. x 0.134 in. thick x 6 in. long (70 mm x 3.4 mm x 152 mm) DOM mechanical steel tubing conforming to ASTM 513 - Type 5, Grade 1026, with a minimum tensile strength of 80,000 psi (551 MPa) and a minimum yield strength of 70,000 psi (483 MPa).

Friction collar: A friction collar manufactured from 3.25 in. o.d. x 0.438 in. thick (83 mm x 11.1 mm) DOM mechanical steel tubing x 3.125 in. (79 mm) long, conforming to ASTM 513, Type 5, Grade 1026, with a minimum tensile strength of 80,000 psi (551 MPa) and a minimum yield strength of 70,000 psi (483 MPa).

See Figure 2 of this report for an illustration of the Push Tube assembly.

Foundation Pier Anchoring Bracket Assembly

Foundation pier anchoring bracket assemblies consist of:

Tube: A 10 in. (254 mm) long tube manufactured from 3⁷/₈ in. o.d. x 3¹/₈ in. i.d. (98 mm x 79 mm) DOM mechanical steel tubing conforming to ASTM 513, Type 5, Grade 1026, with a minimum tensile strength of 80,000 psi (551 MPa) and a minimum yield strength of 70,000 psi (483 MPa).

Angle bracket: A 90 degree angle bracket manufactured from a 0.5 in. thick x 8 in. x 8 in. (13 x 203 x 203 mm) flat plate conforming to ASTM A-36 hot rolled steel, with a minimum tensile strength of 58,000 psi (400 MPa) and a minimum yield strength of 36,000 psi (248 MPa).

Top plate: 5¹/₂ x 9¹/₂ in. (140 x 241 mm) manufactured from 0.75 in. (19 mm) thick ASTM A-36 hot rolled steel, with a minimum tensile strength of 58,000 psi (400 MPa) and a minimum yield strength of 36,000 psi (248 MPa).

ICC-ES legacy reports are not to be construed as representing aesthetics or any other attributes not specifically addressed, nor are they to be construed as an endorsement of the subject of the report or a recommendation for its use. There is no warranty by ICC Evaluation Service, Inc., express or implied, as to any finding or other matter in this report, or as to any product covered by the report.

Cap plate: 4 × 8¹/₂ in. (102 × 216 mm) manufactured from 1.0 in. (25.4 mm) thick ASTM A-36 hot rolled steel, with a minimum tensile strength of 58,000 psi (400 MPa) and a minimum yield strength of 36,000 psi (248 MPa).

Bracket support straps: 2 × 21¹/₄ in. (51 × 540 mm) manufactured from 3/8 in. (10 mm) thick ASTM A-36 hot rolled steel, with a minimum tensile strength of 58,000 psi (400 MPa) and a minimum yield strength of 36,000 psi (248 MPa).

Threaded rod: 3/4 in. (19 mm) diameter × 12 in. (305 mm) long, ASTM A311 Class B Grade 7 zinc plated, with a minimum tensile strength of 133,000 psi (917 MPa) and a minimum yield strength of 115,000 psi (793 MPa).

Nut: 3/4 in. (19 mm) diameter hexhead nut conforming to ASTM A563.

See Figure 3 of this report for an illustration of the Foundation Pier Anchoring Bracket assembly.

CONDITIONS OF USE

This report is limited to the applications and products as stated herein. The ICC-ES Subcommittee on National Codes intends that the report be used by the code official to determine that the report subject complies with the code requirements specifically addressed, provided that this product is installed in accordance with the following conditions:

- # Grip-Tite® Foundation Pier Systems shall be installed in accordance with this report and the manufacturer's published installation instructions by installers certified by Grip-Tite Manufacturing Company. The installation shall comply with the approved construction documents, and this report.
- # Grip-Tite® Foundation Pier Systems shall be limited to applications where the axial loading of the pier assembly does not exceed an allowable load of 16,500 lbs (7491 kg) and the requirements of the construction documents. At a pier spacing of 6 ft (1829 mm), the allowable load per foot of wall is 2750 lb/ft (4.10 kg/mm). These allowable loads are based on the assumption that there is no contact between the footing and bearing soil and do not consider the potential of additional lateral support along the tube shaft provided by surrounding soil conditions.
- # Special inspections of the installation of Grip-Tite® Foundation Pier Systems shall be provided in accordance with Section 1705.9 of the BOCA® *National Building Code*/1999 and Section 113.1.4 of the 1998 *International One- and Two-Family Dwelling Code*®. Items to be confirmed by the special inspector shall include, but not be limited to, evidence of certification of installers by manufacturer, verification of adequacy of soil for installation, the installation pressure of the pier, correct jacking of the foundation onto the pier, and compliance of the installation with the approved construction documents and this report.
- # The use of Grip-Tite® Foundation Pier Systems described in this report is limited to undisturbed soils that have been determined, by the individual responsible for the construction documents required in this report, to provide support of the pier against lateral buckling, and to meet the requirements of Sections 1804.1 and 1804.2 of the BOCA® *National Building Code*/1999 and Section 401 of the 1998 *International One- and Two-Family Dwelling Code*®.
- # Evaluation of the durability of the galvanized coating in the soil, in which the anchoring system is to be placed, is outside the scope of this report.
- # Grip-Tite® Foundation Pier Systems have been evaluated for vertical loading. Other forms of loading are outside the scope of this report.
- # This report is subject to periodic re-examination. For information on the current status of this report, contact the ICC-ES.

ITEMS REQUIRING VERIFICATION

The following items are related to the installation of the report subject, but are not within the scope of this evaluation. However, these items are related to the determination of code compliance:

- ✓ Construction documents, including design calculations, indicating compliance with this report.

INFORMATION SUBMITTED

- # Manufacturer's product literature.
- # *Grip-Tite Manufacturing Company Quality Manual*, dated October 29, 2003 signed by representatives of Grip-Tite Manufacturing Company, and the third-party inspection agency, Froehling & Robertson, Inc.
- # Copies of the AWS certification for welders employed by Grip-Tite Manufacturing Company.
- # Larson Engineering of Wisconsin, Engineering Analysis, dated January 31, 2002, containing information on allowable loading and installation methods, signed and sealed by Steven E. Kaiser, P.E.
- # Stork/Twin City Testing Corporation, Project Number 3618 200-8742.1, dated July 20, 2000, containing axial load testing of the bracket assembly signed by Timothy B. Cox, P.E.
- # Stork/Twin City Testing Corporation, Project Number 3618 199-8240, dated December 23, 1999, containing axial load testing of the 3 in. pier tube assembly signed by Timothy B. Cox, P.E.
- # Froehling & Robertson, Inc., Engineering Calculations, dated January 2, 2003, containing calculations to determine allowable loads relative to material stress limitations, signed and sealed by John H. Nedza, P.E.
- # Froehling & Robertson, Inc., Evaluation Report, dated October 29, 2003, signed and sealed by David E. Stinnette, P.E.

APPLICATION FOR PERMIT

To aid in the determination of compliance with this report, the following represents the minimum level of information to accompany the application for permit:

- # The language "See ICC-ES Legacy Report No. 22-02" or a copy of this report.
- # Construction documents including details and calculations consistent with this report. The individual preparing such documents shall be competent and qualified in the application of the engineering design principles involved, and shall possess registration or license in accordance with the professional registration laws of the state in which the project is constructed. The following items, at a minimum, shall be provided on the construction documents:
 - ! Number, location and required spacing of the piers.
 - ! Placement angles of the piers.
 - ! A soil investigation report for the proposed construction site provided by a registered design professional, qualified to perform such work. Information provided in the soils investigation report shall include, but not be limited to, the following:
 - Soil type at each strata along the length of the proposed pier installation.
 - Allowable soil bearing pressure.
 - Indication of the method used by the registered design professional to determine that the soil is adequate for the proposed installation.

- Properties affecting the design of the system, including the lateral load carrying capacity of the soil at each strata.
 - Location of the ground water table.
 - Maximum anticipated frost depth.
 - The presence or absence of corrosives in the soil and the appropriateness of the use of galvanized steel in the soil.
 - The presence of stone, rocks or other debris in the soil strata and their effects on the suitability of the soil for use with the Grip-Tite® Foundation Pier System.
 - Recommendations to the registered design professional to prevent settlement due to ground water or overloading of the soil, wall damage due to frost heave or corrosion of the pier materials and the characteristics of the appropriate types of loading for the soil.
 - Ability of the system to resist the required seismic forces.
- ! Structural calculations which shall include, but not be limited to, the following:
- Ability of the soil to provide lateral stability to the Grip-Tite® Foundation Pier Systems.
 - Effects of seismic loads on the Grip-Tite® Foundation Pier Systems, where required.
 - Settlement analysis of the piers under design load shall be provided. The analysis shall demonstrate that the Grip-Tite® Foundation Pier Systems transfers the design loads to the soil without causing any stresses within the structure to exceed their respective allowable stress values.
 - Ability of all connections between the building structure and the Grip-Tite® Foundation Pier Systems to transfer the imposed loads.
 - Ability of the concrete slab and/or foundation/footings system to transfer the imposed loads to the Grip-Tite® Foundation Pier Systems.

PRODUCT IDENTIFICATION

Grip-Tite® Foundation Pier System components or packaging manufactured in accordance with this report shall bear the following identification:

"See ICC-ES Legacy Report No. 22-02"

A label that identifies the product and catalog number, the company name, and the third-party inspection agency name or logo (Froehling & Robertson, Inc.).

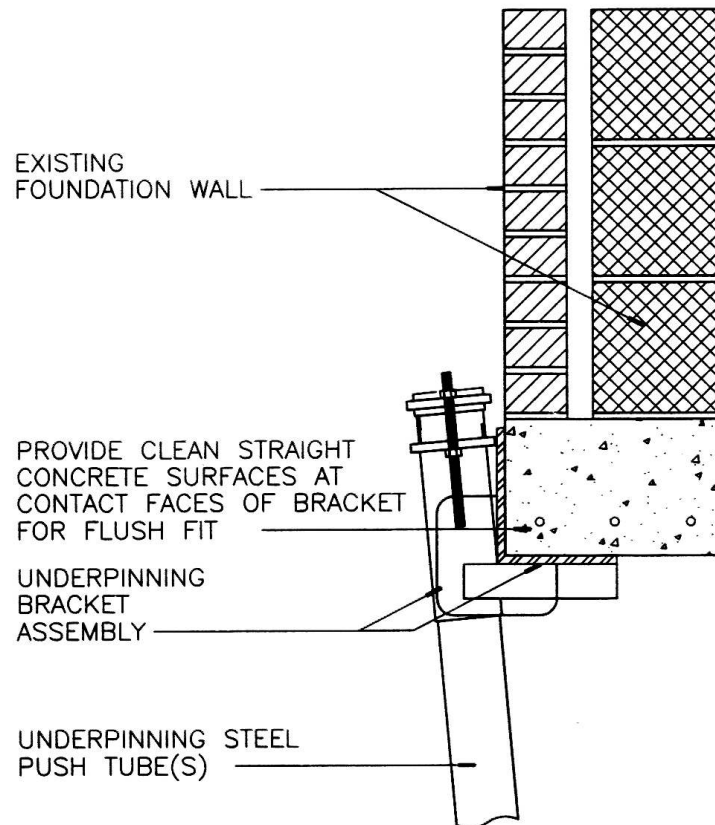

FIGURE 1*—FOUNDATION PIER SYSTEM

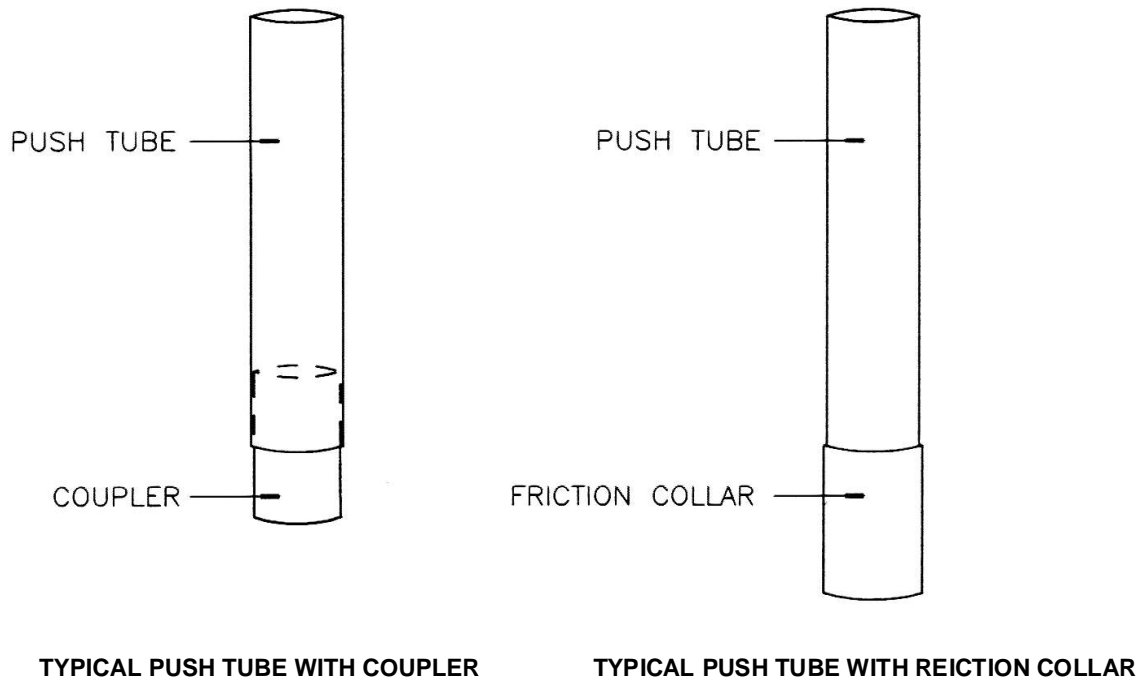

FIGURE 2*—PUSH TUBE ASSEMBLY

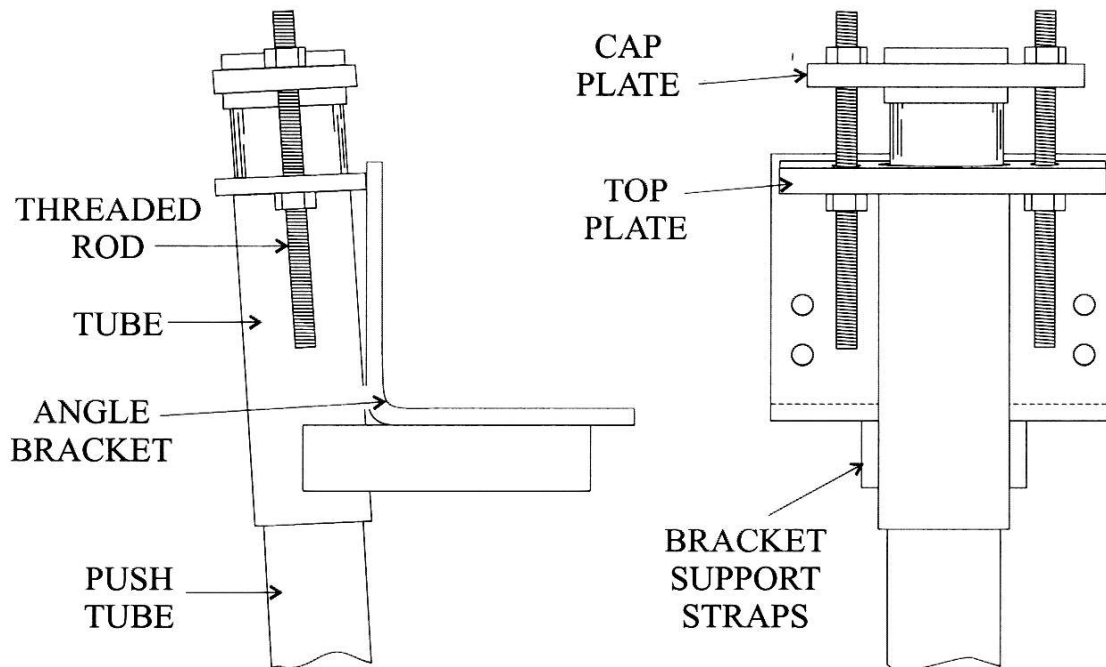

FIGURE 3*—FOUNDATION PIER ANCHORING BRACKET ASSEMBLY

*THESE DRAWINGS ARE FOR ILLUSTRATION PURPOSES ONLY. THEY ARE NOT INTENDED FOR USE AS CONSTRUCTION DOCUMENTS FOR THE PURPOSE OF DESIGN, FABRICATION OR ERECTION.